

The Official Newsletter of the

THE WOODTURNERS

ASSOCIATION OF WESTERN AUSTRALIA INC

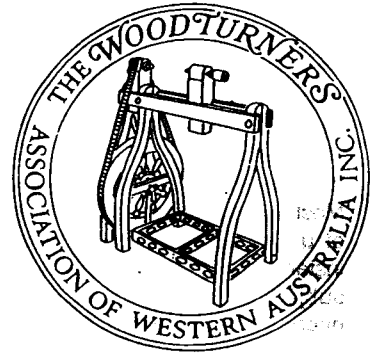

PRESIDENTS COMMENTS	2	HANDY TURNING TOOL	5
JIM'S COACH	2	ALAN FRANCE - PROFILE	6
WEEKEND CALENDAR	2	FOR SALE	6
NOTICE OF AGM	2	PYROGRAPHY CLASSES	6
WEEKEND WORKSHOP	3	SHAVINGS FROM THE COMMITTEE	7
COMPETITIONS	4	1997 COMP ARTICLES	7
COLLIE & BUNBURY - FUN DAY	4	SOCIAL DATES	7
COMBINED WAWA & GSTIG MEETING.....	5		

No:69

JUNE/JULY 1997

If undelivered return to
Woodturners Association of W.A.
P.O. Box 941
West Perth 6872

Print Post Approved
PP643938/0039

**SURFACE
MAIL**

**POSTAGE
PAID
AUSTRALIA**

POST OFFICE
100 WEST PERTH ROAD
WEST PERTH 6872
WEST AUSTRALIA

W.A.W.A. GROUPS MEETING TIMES, DATES AND VENUES.

- BUNBURY.** 1st and 3rd Wednesday. 7pm. Cross Electrics.
- BUSSELTON.** 2nd and 4th Wednesday. 7pm. Venue - High School.
- CENTRAL/SOUTHERN.** 2nd and 4th Wednesday. Brookton District High School.
- COLLIE.** Sundays 9.15am to 4pm. Various home workshops.
- KENWICK.** 1st and 3rd Wednesdays. 7.30pm Liddlelow Homestead, Cooper Avenue, Kenwick.
- MANDURAH.** Every 2nd Tuesday 3pm Mandurah High School, Gibla Street, Mandurah and every 2nd Wednesday on alternate weeks 7.30pm Coodanup Senior High School. Check with Convenor for locations during school holidays.
- MELVILLE.** 4th Thursday. 7.45pm Palmyra Recreation Centre, Cnr Murray Rd and Canning Hwy, Melville.
- MIDVALE.** 2nd Tuesday. 7pm The Woodworking Centre 36 Farrall Road, Midvale.
- MUNDARING.** Every Friday. 7.30pm. Old Parkerville Primary School, Cnr Dura Road and Riley Road, Parkerville.
- NORTH OF RIVER.** 4th Tuesday. 7pm Woodstock 13 Cressall Road, Balcatta.
- WANDI.** 1st and 3rd Thursday. 7pm. Wandi Community Hall, Lot 33 DeHaer Rd, Wandi.

PRESIDENT'S COMMENTS.

From time to time woodturners experience an unexpected turn of events, sometimes pleasant but often one that we could do without. This phenomenon is particularly evident when instructing or demonstrating. I think it is called Murphy's Law!

Most of these experiences have a lesson in them. How many of us have felt sympathy for the poor demonstrator when for instance, the item flies off the lathe? Well, recently I was the subject of some commiseration for one of these unexpected events. With what I thought was plenty of notice, I agreed to demonstrate the making of a pedestal clock. However, my crowded life resulted in me cutting the timber for body and box on the day of the demonstration, using a plank of jarrah (so I thought) of the right colour to match the pedestal I had already prepared.

To my great surprise when attempting to shape the first disc, before the assembled crowd, the gouge produced dust instead of nice curly shavings! A quick dash to the grinder, aha! that will fix it, but no, the tool would still not cut. A change to another gouge fared no better. The first tool now re-sharpened by the master tool sharpener Gordon Ward still produced dust. By now there was an uproar of comment from the crowd and the look on Gordon's face was worth recording!

Reg Watson came up and examined the disc and pronounced the timber to be similar to the unknown Malaysian species which broke two of his new bandsaw blades. Suddenly I then recalled my protesting tablesaw, my one broken and one blunted bandsaw blade and my very hot forstner drill bit when preparing the discs! The mystery wood has yet to be identified, but the lesson is clear. Try the wood at home first.

Happy Turning, Gerald.

LOST BOOK.

A book is missing. It is "WOOD IN AUSTRALIA" by Keith Bootle. The owner of the book is Dan KILGALLON and his name is on the inside cover. Dan would very much like to get this book back. If found, please phone him on (08) 9459 1155.

Country Trips on Jim's Coach

A BIG THANK YOU to Jim for a splendid trip to Kalgoorlie. A contingent of 29 woodturners and associates travelled with Jim on his bus leaving on Friday 18th April and returning on Tuesday the 22nd. In all 1653 kms were traversed in comfort and this included local travelling around Kalgoorlie and a bush trip on the Monday. Weekend Coordinating Committee.

Why not book your trip on the Coach to Toodyay for the August meeting. Give Jim a ring now on (08) 9409 9124.

THANK YOU.

The Weekend Coordinating Committee would like to thank Mike HEAD for re-arranging the PA System into one box and for building two stands for our new halogen lights.

Thanks also to Kevin McCracken for building two feet for our lathe mirror for use on stage where our lathe platform is not needed.

ASSOCIATION WEEKEND CALENDAR

Date: 21st-22nd June 1997
Venue: Loftus Community Centre Leederville.
Competition: Clock, free standing or mantle.
Max face size: 275mm dia.
Host Group: North of the River.

Date: 19-20th July, 1997
Venue: Kalamunda Agricultural Hall Kalamunda.
Competition: Sculptural Form, unrestricted size.
Host Group: Midvale.

Date: 16-17th August, 1997.
Venue: TOODYAY HALL, Toodyay.
Competition: HOLLOW FORM, Vessel or Vase.
Open: 300mm H, 150mm Dia.
Inter/Begin: 250mm H, 100 mm Dia.
Host Group: Toodyay.

Date: 20-21st September, 1997. A.G.M.
Venue: Kalamunda Agricultural Hall Kalamunda.
Competition: GOBLETS max size 75mm Dia x 120 mm tall
Open: 4 matched goblets. Inter: matched pair. Beginners: One goblet.
Host Group: Your Committee.

DEMONSTRATIONS, EXHIBITIONS, SALES.

June 12th - 15th. Traditional Craft Spectacular, Claremont Showgrounds.

August 8th - 10th. WA WOOD SHOW. Claremont Showgrounds.

September 1st - 6th. SOUTHLANDS SHOPPING CENTRE. Burrendah Boulevard, Willetton.

October 13th - 18th. PHOENIX SHOPPING CENTRE. Spearwood.

For further information, please contact:

JOHN LILLYWHITE Phone: (08) 9339 2359

NEIL PIPER Phone/Fax: (08) 9398 2387

KEVIN McCracken Phone: (08) 9310 1057.

Kevin has taken over the drawing up of rosters. Please give him at least two weeks notice of your intended participation.

NOTICE OF ANNUAL GENERAL MEETING.

Please take notice that the ANNUAL GENERAL MEETING of the Woodturners Association of Western Australia (Inc.) will take place at the Kalamunda Agricultural Hall, Canning Road, Kalamunda on Saturday, 20th SEPTEMBER, 1997, at 3 pm.

Members are reminded that nominations for all positions which become vacant shall be on the appropriate form, included with this issue of the Association Newsletter, and lodged with the Returning Officer, by 5pm on Thursday 31st July, 1997. Forms are also available from the Returning Officer, or the Association Secretary.

All Notices of Motion, must be in the hands of the Secretary no later than 15th July, 1997.

George Herring, Secretary.

WAWA WORKSHOP WEEKEND AT LEEDERVILLE
21st – 22nd JUNE 1997

Loftus Community Centre, Cnr Richmond and Loftus Streets, LEEDERVILLE.

NORTH OF THE RIVER Group welcome all WAWA members, spouses and visitors. The theme of our weekend is: INNOVATION KEEPS YOU THINKING, THINKING KEEPS YOU YOUNG.

CONVENOR: Jim Bell
MC: Viv Paust
HOSTS: All Committee Members.
HOSTESS: Verna Paust.
SAFETY ADVISERS: Gordon Ratcliffe, Theo Linders.
HANDS-ON: Les Taylor – Tool sharpening instruction. Four Grinders available with pre-set rests so you can "get it right"! In addition, there will be a glass sandblasting booth available for use in conjunction with the glass work demo.

COMPETITION ITEM: CLOCK – Free standing or mantle. Maximum Face size 275 mm Dia.
TRADE SUPPLIER: WOODSTOCK

PROGRAMME: SATURDAY 21st JUNE

8.00 am Set up venue.
9.00 Welcome, announcements and Trade Supplier talk.
9.15 Demo 1 – Steve McCann – Glass and the Turner – Part 1.
10.00 MORNING TEA.
10.30 Demo 2 – Chris Murdoch – Inlays with Mother of Pearl.

For the Ladies. Part 2 of Steve McCann's demo will be directed to both the ladies and the men.

11.15 Demo 3 – Steve McCann – Part 2– Unisex glasswork.
12.00 Competition entries close. Voting commences. LUNCH – Sausage sizzle.
1.00 pm Demo 4 – George Rice – Standard Lamp and base.

Alternate Programme. Silk Ribbon Embroidery with Lee Chase. Smocking with Jo Bungey.

2.00 Demo 5 – Bob Webb – Glass in an undercut bowl rim.
3.00 AFTERNOON TEA
3.30 President's Report / Forum.
4.00 Guess the Wood. Competition Results. Show and Tell.
5.00 Close

PROGRAMME SUNDAY 22nd JUNE

9.00 am Welcome and Announcements.
9.15 Demo 1 – Chris Brown – French polishing expert/instructor.
10.00 MORNING TEA
10.30 Demo 2 – Viv Paust – The Safe Turner – Spindles / faceplates.
11.15 Demo 3 – Ray Bowra – Turning fruit on a lathe.
12.00 noon LUNCH – BYO.

1.00 pm DISCUSSIONS WITH EXPERTS – EMPHASIS ON DESIGN AND FINISHING FOR COMPETITIONS.

What's pleasing and what isn't? Why enter competitions? What do judges look for? To what extent is judging subjective? What competitions are available for woodturners? Are we doing enough to encourage people to enter competitions? What more can we do? Should we be using our Show and Tell to assist this process more? If so how? Is there enough integration of group meetings and W/E workshops in respect to competitions?

2.00 CLEAN UP and LOAD TRAILER.

WAWA WORKSHOP MEETING AT KALAMUNDA
19th – 20th JULY 1997

Kalamunda Agricultural Hall, Canning Road, Kalamunda. MIDVALE Group welcomes all members, partners, friends and visitors to their workshop weekend.

CONVENOR: Jim McDonnell. MC: Ken Locke.
HOSTS: To be arranged.
SAFETY ADVISER: Kevin McCracken.

COMPETITION ITEM: SCULPTURAL FORM. May be functional or aesthetic, free standing or hanging. Size unrestricted.

TRADE SUPPLIER: TIMBECON.

PROGRAMME: SATURDAY 19th JULY.

8.00am Chuck Wagon Arrives, venue set up (all assistance welcome.)
9.00 Announcements. Vacuum chucks with Milton Rundle.
10.00 MORNING TEA, please bring a contribution.
10.30 New ORGANOIL products – a representative from ALDON DISTRIBUTORS will give us the good oil on this.
Alternative: Take a stroll or a car ride to Kalamunda History Village – more details on the day.
10.45 Neil Piper making Jewellery.
12.00 Competition entries close, voting commences. LUNCH – SAUSAGE SIZZLE Lesmurdie Scout Group.
1.00pm Bob Nichols demonstrating the making of rectangular (also known as square edge) bowls.
Alternative: Phyllis Dillon introduces you to the art of Decoupage.
2.00 Turned Toys with Eric Walker – don't forget the toy drive will be on again this year.
3.00 AFTERNOON TEA.
3.30 Goblets by Gordon Ward. Goblets are the subject of the competition in September.
5.00 CLOSE.

REMINDER. July marks the 10th Anniversary of the founding of the Midvale Group so if you have any photos, turning or other memorabilia of the early days, please bring it along and put it in our special display.

PROGRAMME: Sunday 20th JULY.

9.00am John Brooks will show us some of his techniques.
10.00 MORNING TEA.
10.30 Ken Rex shows us how to use carving tools and relates this to the embellishment of turned items.
11.00 Competition Voting Closes.
11.30 Viv Paust – How to get the best finish off the tool.
12.30 LUNCH. Bring your own or buy at shops nearby.
13.30 Show and Tell, Competition results, President's Forum. Followed by the big clean up and loading the trailer. All hands please.

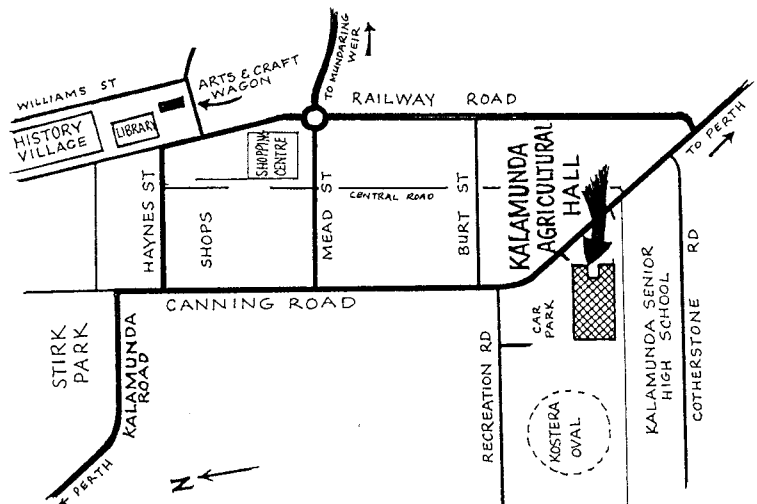

COMPETITION MARCH – MELVILLE.

Bowl with undercut/rolled rim.

This months competition was again well supported with an even spread of entries throughout each category. The majority of the Turners used Sheoak or Jarrah in one form or another and the quality of the work from all the participants is to be commended. I'd like to thank Ken Rex and Keith Johnson, for providing a written critique on all the entries and to Kevin McCracken for his presentation of the Show and Tell.

RESULTS

Beginners.	1st	Alan Smith – Sheoak	(64)
	2nd	Brian Fowlie – Sheoak	(62)
	3rd	George Herring – Sheoak	(60)

Intermediate.	1st	Jan Jurewicz – Sheoak	(41)
	2nd	Reg Watson – Jarrah	(44)
	3rd	Bob Webb – Jarrah/Sheoak	(46)

Open.	1st	Gordon Ward – Jarrah	(28)
	2nd	Alan France – Jarrah	(24)
	3rd	Bob Nichols – Jarrah	(26)

Ladies Choice: Gordon Ward

COMPETITION APRIL – KALGOORLIE.

Maximisation of Wood 75mm x 75mm x 300mm.

My thanks to Eric who was kind enough to take my place and provide the comments on the competition for Kalgoorlie. That this is possibly not one of the more popular subjects was reflected in the low number of entries in the lower classes. However, great ingenuity was shown by most competitors with single items, multiple items, laminations etc. One competitor brought the remains of the block to show how items were cut from it, another brought his drawings to prove it was possible to get a large bowl from a small block.

As usual, the entries were generally of a high standard. Items included goblet, pepper mills, candlesticks, laminated vases and even a tulip. Some of the work of the lower classes indicated that the turners should consider moving up a class. The results indicate that voting was for the right reason – maximal use of wood – and not purely for aesthetic reasons. Thank you and congratulations to all competitors. The critique was conducted by Bob Holloway and Robin Halbert.

Eric Walker.

RESULTS.

Beginners.	1st	Alan Smith – Unknown	(60)
	2nd	Brian Fowlie – Jarrah	(62)

Intermediate.	1st	Peter Dessent – Sheoak	(40)
	2nd	Jim McDonnell – Jarrah	(43)
	3rd	Reg Watson – Maranti	(41)

Open.	1st	Alan France – Jarrah	(24)
	2nd	Val Periera – Sheoak	(22)
	3rd	Viv Paust – Sheoak	(21)

Ladies Choice: Val Periera.
Competition Organiser – Peter Dessent.

WOMENS TURNING DISPLAYED AT KALGOORLIE.

As a result of an idea to display some of the work done by women turners, Margaret Young organised a display of work at the Kalgoorlie Weekend. Despite the distance between lady turners and Kalgoorlie, Margaret and her helpers were able to exhibit a good range of their craft. The variety and freshness of approach, together with innovation, created much interest including newspaper

coverage by the Kalgoorlie Miner.

As a result of this, WAWA organisers wish to have a repeat display at the AGM in September. As there were many women who expressed willingness to contribute to the display but for various reasons were unable to do so, we will be confident of a wider number of contributors next time.

For any enquiries, please contact Margaret Young of Kellerberrin (08) 9045 4382 or myself, Elaine Boyd (08) 9361 1461.

ORNAMENTAL TURNERY

WAWA has joined The Ornamental Turners Group of Australia. Ornamental turning has been described as the practice of decorating or embellishing plain turned objects by mechanical means, in order to enhance the appearance and/or function. It is the technique and equipment employed by which the end result is achieved that defines this particular form of creative and artistic endeavour.

There are two distinct forms of ornamental turning, the first is the surface decoration of plain turned articles, the second is the production of compound solids and the subsequent ornamentation of their surfaces by mechanical means in a very precise manner.

This group publishes quarterly newsletters which will be available through our Newsletter Librarian – Len Nicholls.

COMMITTEE CHANGE.

Bob POWER resigned as a member of the Committee of Management effective from the 28th April, 1997. In accordance with Clause 16 of the Constitution of the Association, the Committee of Management has appointed George HERRING to the Committee to hold Bob POWER'S place until the next Annual General Meeting. You will recall that at the 1996 Annual General Meeting, Geoff BARKLA and George HERRING tied with equal votes and Geoff was elected on the toss of a coin. Gerald Young, President

☺ COLLIE AND BUNBURY - FUN DAY. ☺

The Collie and Bunbury Groups held a Fun Day at Wallsend Ground on Sunday, the 4th May. Although there was a smaller turnout than expected, everyone who attended had an enjoyable day. The object of the day was to mix socially and enjoy the company of other turners from "Over the Hill" (not, I must stress, over the hill turners). Even the infamous Collie weather managed to oblige.

The day wasn't completely without competition. Members were divided into two groups, given one piece of wood and one tool of their choice and asked to turn a carry bag holder, giving each member of their group an opportunity to add his individual "thing". The groups would like to thank Gerald Young for travelling to Collie for the day, and for judging the competition. It is hoped other fun days of this nature will be organised on a regular basis. Joan Stanton.

When you can keep your head, and all about are losing theirs, it is evident that you don't know how serious the situation is.

THE WOODTURNERS ASSOCIATION OF WESTERN AUSTRALIA.

ELECTION OF OFFICE BEARERS 1997/98.

The Election of Office Bearers of the Association will be held at the Annual General Meeting to be held in conjunction with the Association's Workshop to be held on the 20th September, 1997.

There is no postal, absentee, or other form of voting.

The term of office of the following members will expire at the Annual General Meeting.

PRESIDENT **Gerald YOUNG**

**COMMITTEE
MEMBERS:**

Michael HEAD
George HERRING (Bob POWER resigned
28th April, 1997)
Kevin McCRACKAN
Les SMALL
Neville THRELFO

The term of office for the President is one year, while the term of office of the Committee Members is two years.

A valid nomination must be signed by a proposer and a seconder and include the consent of the member to serve if elected.

Please use the form, printed on the reverse of this notice, and post or deliver it to the Returning Officer:

Mr Richard LEGGO
21 Rockton Road
NEDLANDS WA 6009

not later than 5pm on Thursday, 31st July, 1997.

THE WOODTURNERS ASSOCIATION OF WESTERN AUSTRALIA
ELECTION OF OFFICE BEARERS 1997/98

NOMINATION FORM

I _____ Membership No. _____
(Nominating members name)

wish to nominate

_____ Membership No. _____
(Name of proposed office bearer)

to be elected to the office of PRESIDENT* COMMITTEE MEMBER*

_____ at the election to be held on the 20th September 1997.

_____ (Signature of Nominating Member.) Date: ____/____/1997.

I second the nomination.

_____ (Signature of the Seconder.)

Name of Seconder _____ Membership No. _____

I accept the nomination and agree to serve if elected.

_____ (Signature of proposed Office Bearer).

* Cross out whichever does not apply or write the name of the office being sought.

NOMINATIONS CLOSE WITH THE RETURNING OFFICER on or before 5pm, 31st JULY, 1997.

Returning Officer: Mr R L Leggo 21 Rockton Road Nedlands WA 6009

COMBINED WAWA / GSTIG MEETING AT KALGOORLIE.

For those who were fortunate enough to be able to attend this weekend, the long trip proved to be more than worthwhile. Thanks must go to the members of the Goldfields Specialty Timber Industry Group who did a sterling job in setting up the facility and running this excellent weekend and also to Gordon Ward who was the liaison member from WAWA.

It would be safe to say that it was the most successful use of multiple demonstrations that has been held. A large number could be seated around the main platform and the use of two video cameras transmitting to two large TV screens proved to be far superior to any other system we have used.

The concurrent demonstrations had a consistent audience moving from one to the other and everyone gained a great deal from the various skills shown.

While the entries to the competition were rather low in number, there were excellent displays of work by our lady turners, by members of GSTIG and particular mention should be made of the display by students of John Paul College. From virtually no experience, but with guidance from Gordon Ward, the students produced work, which everyone agreed, was both artistically meritorious and skilful.

The evening meal at the Bowling Club was followed by a fascinating glimpse at the history of the Woodlines. These were the light railway lines which extended out through the eucalypt forest surrounding Kalgoorlie in order to bring in the vast amount of fire wood needed to keep the mines operational. Ian Kealley presented a series of slides taken in the early days of the Woodlines and this was followed by excerpts from Bill Bunbury's award winning documentary. Bill also highlighted some of the aspects from his time making the documentary. This was a valuable insight into some of our unique WA history.

I was unable to go on the bus tour on the Monday, but I would urge attendance at any future meetings in this historic town.

Robin Halbert.

VIC WOODS METHOD OF FREEZING TIMBER.

Reproduced thanks to The Yarra Turners.

1. **TURN** outside of bowl, sand to satisfactory finish.
2. **RECHUCK** and complete the inside.
3. **USE** vacuum plate to remove unwanted chuck marks on base, sand. A finish of Organoil, Rustins Danish Oil or Urethane can be applied as you finish each section. (one coat).
4. **PLACE** the finished bowl in a plastic bag and put in the freezer for at least 24 hours.
5. **TAKE** bowl from the freezer, remove plastic bag, thaw out, then place in the refrigerator and this will allow it to dry out gradually. (Must not be in plastic bag).
6. **LEAVE** in the refrigerator for up to 10 days. A bowl up to 3/8" thick should dry in this time.

If you wish, you can weigh the bowl before putting it in the freezer. The theory is that in the freezer the cells are perforated by the freezing and then in the refrigerator the moisture is taken out of the wood (like bread or meat drying out if it is not covered with Glad Wrap).

If removing from the refrigerator in hot weather, it is advisable to wrap the bowl in a paper towel, or put in a brown paper bag, so that the timber acclimatizes to the atmosphere slowly. Do not use newspaper as the print will be absorbed into the

timber. Keep the bowl in a cool spot. After the bowl has stabilized to normal temperature, cut back with 4/0000 steel wool, webrax or a fine scotchbrite mop, then proceed with your normal finishing of the wood to obtain a suitable lustre. Finally polish with a swansdown mop.

Some woods I have found work better than others. Red Gum, Camphor Laurel, Blackwood, Sassafras and Huon Pine all seem to work well. Other woods do not crack but may distort. If the section of wood is quarter sawn it tends to work more effectively than live sawn blanks. I do not know for sure, but if the wood (bowl) has not been in the refrigerator for at least 10 days, it can even warp after it comes out. This I believe because all the excess moisture has not been removed. Up till now I have not had one bowl split, but some have warped. I did have a redgum bowl 10" x 1.75" with a crack in the edge and it had warped. It was still wet. I followed the above process and the bowl flattened out and the crack closed up.

Good luck, it worked for me, I hope it works for you.

Vic Woods.

HANDY TURNING TOOL.

A lot of members will have already seen the turning tool in the drawing shown, some members have made them and use them very effectively.

It came about almost by accident. It was during a visit in 1989 by a lace bobbin maker, David Springett, who has gone on to write two very successful books. David was lecture touring on the history of lace bobbins.

At one stage he was talking of a tool called a BUCKINGHAMSHIRE SKEW. He explained the design of the tool which I thought I understood. But No! Instead of grinding across the corners of an oblong section of steel, I did the same to a square section, resulting in the tool you see in the drawing.

The tool sits very safely on the top of the tool rest, setting the tip of the cutting at 45° to the wood being cut. This is a shear scraping tool. I have used it in and out of goblets, bowls, and some spindle turning. Make one and experiment.

Ivor Bridges.

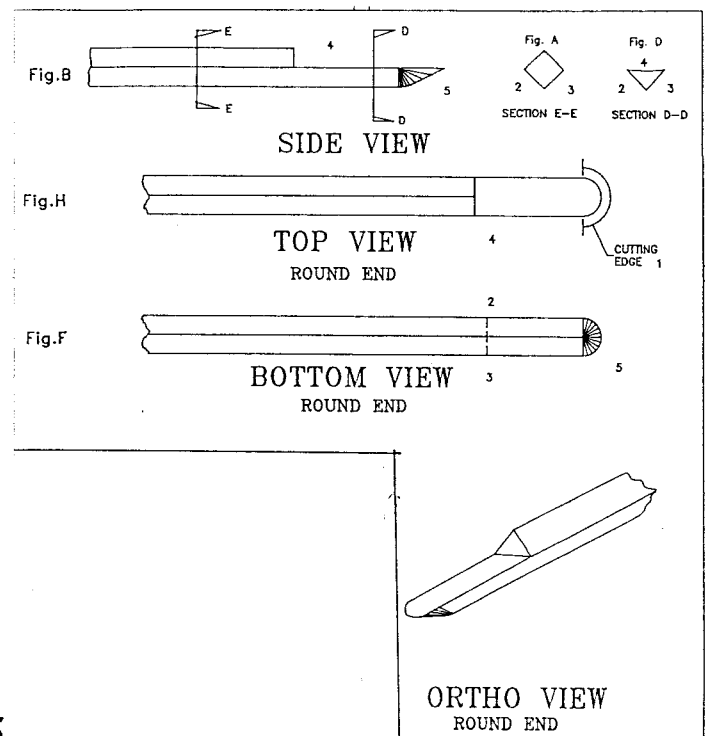

PROFILE OF A TURNER

ALAN FRANCE

Alan France, arguably one of WAWA's best turners, is another of our genuine Sandgroppers. He was born in Vincent Street, North Perth, overlooking the football ground. Alan's father was a jeweller and watchmaker.

His father's business was in Katanning and Alan's primary schooling began there, but at age 9 the family moved to Subiaco where his primary schooling was completed. Alan's secondary schooling was undertaken at the Junior Technical School in Newcastle Street, where, in addition to the normal academic subjects, instruction was given in technical drawing, metal work, wood work and blacksmithing. He successfully obtained his Junior Certificate at the school.

While still at school, Alan bred and competed with racing pigeons as a member of the junior section of the Subiaco Racing Pigeon Association. A loft was built in the back yard of their home and Alan built his own time clock for the timing of the birds flights. He had about 40 birds and continued this hobby for about four years.

After completing his Junior Certificate, Alan obtained an apprenticeship with the WAGR at the Midland Workshops as a pattern maker. This entailed making a huge variety of different patterns for mouldings of articles as diverse as handles and brake pads through wagon and engine wheels to a propellor for the State Ship Kanimbla. The patterns were made in yellow pine as this gave minimum warping and the moulds would be made from these patterns.

For a change of scene, Alan then went with his brother crayfishing in the Abroholos Islands. In between pulling cray pots, Alan partook of one of his favourite pastimes, which is wet line fishing. During one of these trips, he managed to put a hole in his boat which, unbeknown to him at the time, was very close to where the wreck of the Batavia was ultimately discovered. In between fishing seasons, Alan worked at Chamberlain Tractors as a pattern maker.

Alan says in many ways the crayfishing and fishing were one of the highlights of his life, but having met and proposed to Maxine, the long periods away and the uncertainties, he decided to leave crayfishing. As a point of interest, he was offered a fishing boat, together with licences, for £500, a far cry from today's prices.

Having always had an ambition to be a teacher, Alan then enrolled at Teachers College and trained as a Manual Arts teacher. Over the years, he taught at Fremantle Boys, Geraldton, Cyril Jackson and Como Senior High School.

While woodturning was part of his trade as a pattern maker, it was mostly with scrapers and skew chisels and practically never with gouges. At the Midland Workshops there was a huge wood turning lathe which had a travelling post and they used a ring gouge for making patterns for cylinder rings for steam engines. They would turn slightly tapered cylinders and then cut them into rings from which the moulds were made.

In the schools, only a limited amount of turning was done and he had never used high speed steel tools until he joined WAWA. Joe Saat introduced Alan to WAWA and most of what he has learnt has been learnt in the Association. He has obviously learned well as he consistently wins the weekend competitions and the highest points for the year competition. In particular, he is renowned for the accuracy of his joins in his segmented work and the innovative forms he has

accomplished.

He is a popular and extremely competent demonstrator and his demonstrations are always eagerly attended. Alan is a great asset to our Association.

PYROGRAPHY CLASSES

(Wood Burning) Now Available.

Learn this craft from the Expert. Steve Makin is a true professional with considerable skill and expertise.

Places are now available for Weekdays and Saturday mornings at very affordable rates.

Ring now to reserve your place.
Phone/fax (08) 9314 2226

We also have BEGINNERS CLASSES in Wood Turning starting weekly. Phone Peter for details.

Southside Woodturning Supplies
6 Harrison Street, Willagee.

FOR SALE

DOUBLE VEE BELT PULLEY - easily converted to a BOWL LATHE. Phone David Lathwell (08) 9764 1057

RECORD R.P.T.V. 100 TURBOVISER. 8 hour 150 lt. New Condition. 18 hours use. \$395.

SCANGRIND WET GRINDER 150 Extra Jig. \$130.
Phone Jack Connolly (08) 9384 3509. Member No 1317

TEKNATOOL TL1000 WOOD LATHE, 8 speeds on a timber stand, 3/4 hp motor. \$750.
Phone Jim Pember (08) 9409 9124 Member No. 802

LARGE PHILIPS 700 WATT CAROUSEL MICROWAVE oven for drying your wood. \$50.00 O.N.O.
Phone Peter Dessent (08) 9398 1297.

WOOD. Russell Clark of RMB 367 Kojonup, has available BLACKBOY STUMPS, all solid, topped and tailed at \$1.20 kg delivered to Perth and districts. He also has available REDGUM, JAM and WHITE GUM BURLS, green or dry, large and small. Solid slabs including furniture grade timbers are also available. Phone Russell on (08) 9856 6248.

Please note: The postal address for George Herring, our Secretary, has changed to:

Post Office Box 371
KELMSCOTT WA 6111.

Please use this address for all future correspondence sent to George.

Phone Contacts:

President:	Gerald Young	(08) 9399 5002
Secretary:	George Herring	(08) 9495 4147
Treasurer:	Milton Rundle	(08) 9385 9559
Editor:	Robin Halbert	(08) 9322 2633
Membership Secretary:	Cheryl Russell	(08) 9337 7631

WOODTURNERS ASSOCIATION OF WESTERN AUSTRALIA - COMPETITION ARTICLES FOR 1997.

21-22nd JUNE and 19 - 20th JULY. See page 3 this issue.

16-17th August. HOLLOW FORM, Vessel or vase. OPEN: 300mm H, 150mm Dia
INTERMEDIATE / BEGINNERS: 250mm H, 100mm Dia.

20-21st September. GOBLETS maximum size 75mm Dia x 120mm tall. OPEN: 4 matched goblets
INTERMEDIATE: Matched pair. BEGINNERS: One goblet.

18-19th October. TABLE LAMP - Inside out or Offset Turned. Maximum: 400mm H.

15-16th November. WALKING STICK. Must be turned from a single unsplit piece of timber. Handle free choice.

20th December. Best Thing Turned Competition Results and Biggest "STUFF UP" Of The Year.

17th January, 1998. PAIR OF SALT AND PEPPER GRINDERS, or A CRUET SET.

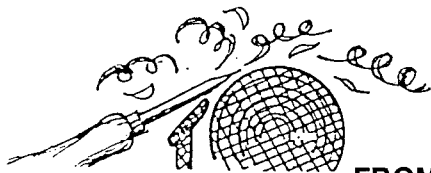

SHAVINGS FROM THE COMMITTEE

APPLICATION FOR LOTTERIES COMMISSION GRANT.

The Management Committee has recently completed a forecast of anticipated new equipment needs for the coming twelve months and based on this forecast, an application has been lodged with the Lotteries Commission seeking a grant to assist with the cost.

SEARCH FOR ASSOCIATION PREMISES.

In its continuing search for suitable premises for an Association Headquarters, members of the Management Committee have recently followed up two prospects. One involved a proposed development by the City of Belmont. Upon investigation, this proved to be unsuitable for the Association's needs. The other was an unused church property in Bayswater offered for freehold sale at a cost of \$259000. This property had potential, but only had limited on site parking.

The method of financing any acquisition has not yet been investigated in detail. It is now proposed to undertake an examination of financing options available and to present these to the members for consideration and decision, as a guide for action, when another prospective location becomes available.

COMPETITIONS - REGISTER OF INTERESTED MEMBERS.

The Association Secretary receives literature on competitions being conducted. Time constraints make it difficult to contact members who may be interested in participating and it is impractical from a cost basis to advise the general membership. To overcome this problem, it is proposed to establish a Register of Members interested in receiving advice of such events. Members who require advice of these events are requested to lodge a written Registration of Interest notice to have their names recorded on the register.

DONATIONS FOR OUR REFERENCE LIBRARY.

Two books have very generously been donated to our Reference Library. These are:

- THE EUCALYPTUS BOOK Volume 2 Donated by Gordon Ward and
- WOOD IN AUSTRALIA donated by Gerald Young. Thankyou Gordon and Gerald from the Management Committee and the general membership.

THE CYRIL JONES MEMORIAL TROPHY.

In memory of our late Past President, the Committee introduced the Cyril Jones Memorial Trophy which will be awarded to the competitor with the highest number of cumulative points received in the Royal Agricultural Society competition for woodturning entries at the Royal Show.

MEMBERSHIP OF OTHER ASSOCIATIONS.

WAWA has recently become a member of the AMERICAN WOODTURNING ASSOCIATION and the ORNAMENTAL TURNERS GROUP OF AUSTRALIA. We are also currently in the process of taking out membership of the NEW ZEALAND WOODTURNERS ASSOCIATION. This will result in WAWA receiving the journals from the respective organisations and these will be available to interested members.

SOCIAL FUNCTIONS.

NOTE: Date changed for December Function at Miss Mauds.

SOCIAL FUNCTION DATES FOR YOUR DIARY.

Date: 26th JULY, 1997.
Venue: MISS MAUD'S FUNCTION CENTRE,
Cnr Pier and Hay Streets, PERTH.
Cost: \$19.50 per head for a buffet meal.
Drinks: A separate Cash Bar will operate.
Seating: Limited to 90 people - BOOK EARLY !!!
Parking: Adequate public car parking available nearby.
Contact: Cheryl Russell Phone (08) 9337 7631

Date: Now the 13th DECEMBER, 1997.
Venue: MISS MAUD'S FUNCTION CENTRE,
33 South Terrace, FREMANTLE.
Cost: \$18.50 per head for a Christmas buffet lunch.
Drinks: A separate Cash Bar will operate.
Seating: Adequate for our needs. 152 attended in 1996.
Parking: Adequate public car parking available nearby.
Contact: Cheryl Russell Phone (08) 9337 7631

**TO GIVE UP ENTHUSIASM
WRINKLES THE SOUL.**

Samuel Ullman

WOODSTOCK

Timber Tools & Hardware PTY LTD

BALCATT

13 Cressall Road, Balcatta WA 6021
Phone (08) 9345 4522 - Fax: (08) 9240 1014

TONKIN BUSINESS PARK
8 May Holman Drive Bassendean
Phone (08) 9377 0277

BIBRA LAKE

44 Pt Kembla Drive, Bibra Lake
Phone (08) 9434 9088

TIMBER

PINE
JARRAH
TAS OAK
SHEOAK
WANDOO
TUART
POPLAR
ASH
WALNUT
CHERRY

JELUTONG
MAHOGANY
TEAK
AM RED & WHITE OAK
EBONY
BLACKWOOD
MALAY KAURI
NYATOH
MERANTI
W.R. CEDAR
OREGON

TIMBECON PTY LTD

LATHES TOOLS

SAWS

JAPANESE TOOLS

SINGLEY DRUM

SANDERS

SHARPENING STONES

WOODTURNING TOOLS

WOODCARVING

SPOKESHAVES

PLANES

10 John Street
BENTLEY 6102
PHONE 356 1653
FAX 9321 4200

CRAFT ACCESSORIES



Willetton Hardware

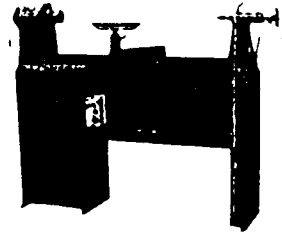

PRODUCT

Makita power tools, Triton work centre, Tough lathes, band saws, linishers, Woodfast lathes, clock movements, Sorby woodturning chisels, barometers, thermometers, hygrometers

SERVICES

Saw and tool sharpening, key cutting
Open 7 days per week

CONTACT TIM CRITCHELL

PHONE (08) 9457 8323

ADDRESS 3/9 AUGUSTA STREET
WILLETTON



W.A.'S

WOODTURNING CENTRES



CROSS ELECTRICAL SUPPLIES
90 BLAIR STREET, BUNBURY
PHONE (08) 9721 5858

THE WOODWORKING CENTRE
36 FARRALL ROAD MIDVALE WA 6056
PHONE (08) 9274 5655 FAX (08) 92501584

ALL YOUR NEEDS FOR:

LEISURE ACTIVITIES WITH WOOD

WOOD LATHES: Tough, Woodfast, Teknatool, Durden, Vicmark
WE HAVE:

THE EQUIPMENT AND ASSOCIATED CRAFT ACCESSORIES
CHISELS, BOOKS, VHS TAPES AND CAN ORGANISE YOUR LESSONS

SOUTHSIDE WOODTURNING SUPPLIES SPECIALISTS IN WOODTURNING & WOODWORKING MACHINERY

- Wood Turning Lathes
- Dust Extractors
- Bench Grinders
- Thinknessers
- Lacquers & Finishers
- Clock Movements
- Bandsaws
- Table Saws
- Floor & Bench Drills
- Assorted Timbers
- Carving Tools
- Tiles
- Scroll Saws
- Wet Stone Grinders
- Linishers
- H.S.S. Turning Tools
- Brass Ware
- Cutlery Blanks

PHONE (08) 9314 2226

Unit 2, 6 Harrison Street Willagee

MAIL ORDERS WELCOME

Classes held Mondays, Tuesdays, Fridays and Saturday morning
Instructors Russ Russell and Rodney Cocks

ROTARY CHISEL

-THE CHISEL WITH THE EDGE-

- CUT GRIND SHAPE WOOD
- TNGSTEN CARBIDE TEETH
- FAST SHAPING & CUTTING
- OUTSTANDING FINISH
- SMOOTH AND PREDICTABLE
- GUARD ENSURES USER SAFETY

PH/FAX 08 9791 1643
P.O. BOX 1095 BUNBURY

T-Gem

Wood Lathes

Australian Made

3 Std sizes or to order

10" x 30"bc Live Centre, Camlocks

16" x 36"bc Hollow Tailstock

18" x 48"bc Indexing, No2 Morse

Barnwell Engineering Developments
5/2, James Street, BAYSWATER,
W.A. 6053 Ph or Fax (08) 9272 8033

QUALITY PEN MECHANISMS

(we mean quality!)
at realistic prices

5-20 \$3.10ea
21-50 \$2.85ea
51-100 \$2.60ea
101-199 \$2.50ea
200+ \$2.20ea

Freight & insurance extra

P-SQUARE AGENCIES

P.O. BOX 1620 BOORAGOON WA 6154
Phone/Fax 08 9314 1513

precision WOODCRAFTS

CLOCK CRAFTS SUPPLIES AND ACCESSORIES

Quality clock movements, weather instruments, dials, numerals, musical movements, pen funnels and LOTS MORE.

MAIL ORDERS WELCOME

7 Wildwood Heights
Leeming, W.A 6149
Tel: 08-9332 4481
Fax: 08-9332 6811

Special discounts for club members

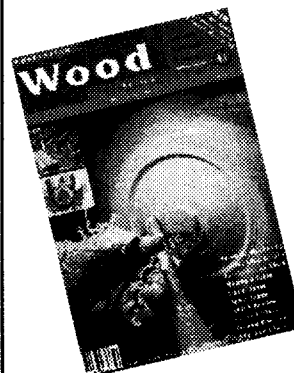

Along with furniture, carving, tools, machinery, equipment and timber, Australian Wood Review also features woodturning. Each issue lets you tackle a project, re view a tool, check out the local & international scene or visit a top woodturner at home. Get your copy of Wood Review from newsagents or call the subscription hot-line on (07) 328 77088