

THE WOODTURNERS

ASSOCIATION OF WESTERN AUSTRALIA INC

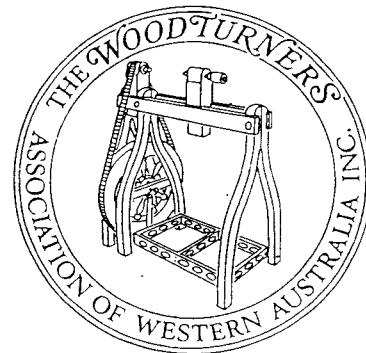

PRESIDENTS REPORT	2	ANNUAL ACCOUNTS.....	5
WEEKEND CALENDAR.....	2	STEPHEN HUGHES	5
DEMONSTRATIONS	2	COMING EVENTS	6
WORKSHOP MEETINGS	3	GOLDFIELDS GROUP	6
BROOKTON COMPETITION.....	4	SOLA TIMBER KILN	6
ANNUAL PRESENTATIONS	4	SANDING TABLE.....	7
NEW PRODUCTS FEATURE.....	5	COMMITTEE PHONE NUMBERS.....	7

No:50

FEB. MAR. 1993/94

If undelivered return to
Woodturners Association of W.A.
P.O. Box 941
West Perth 6872

Print Post Approved
PP643938/0039

**SURFACE
MAIL**

**POSTAGE
PAID
AUSTRALIA**

L. NICHOLLS 559
688 PRESTON POINT ROAD
EAST FREMANTLE 6158

W.A.W.A. GROUPS MEETING TIMES, DATES AND VENUES.

- AVON VALLEY.** 3rd Thursday 7.30pm Venue. High School.
- BUNBURY.** 1st Wednesday, 3rd Friday 7pm. Cross Electrics.
- BUSSELTON.** 1st and 3rd Wednesday 7pm. Venue. High School.
- CENTRAL/MIDLANDS.** 4th Saturday of every month. Moora High School. (Depending on availability of venue).
- CENTRAL/SOUTHERN.** 2nd and 4th Wednesday. Brookton District High School.
- COLLIE.** Sundays 9.15am to 4pm. Various home workshops.
- KENWICK.** 1st and 3rd Wednesdays 7.30pm Liddlelow Homestead, Cooper Avenue, Kenwick.
- MANDURAH.** Every 2nd Tuesday 3pm Mandurah High School, Gibla Street, Mandurah. Check with Convenor for locations during school holidays.
- MELVILLE.** 4th Thursday 7.30pm Palmyra Recreation Centre, Cnr Murray Rd and Canning Hwy, Melville.
- MIDVALE.** 1st Friday 7pm At the rear of The Woodturning Centre, Stanhope Gardens, Midvale.
- MUNDARING.** Every Friday. 7.30pm. Old Parkerville Primary School, Cnr Dura Road and Riley Road, Parkerville.
- NORTH OF RIVER.** 4th Tuesday 7pm Balga TAFE Campus, 18 Loxwood Road, Balga.

PRESIDENT'S REPORT.

I have received grateful letters of acknowledgement from the organisations to whom gifts of toys were made in December, so I would like to take this opportunity to pass on sincere thanks to all those who were involved in our Christmas toy-making venture. I was particularly touched by the message from the Red Cross Lady Lawley Cottage - "for these children, every step is an achievement."

It is becoming an Association tradition, and what better New Year Resolution could we make than to open UP the workroom door, sharpen UP our tools, pick UP some material, start UP our machines, gear UP for production and brighten UP some young lives. (With apologies to Probus News).

It may be too early to be thinking about December, 1994, but while the Mulberry Farm Function is fresh in your minds, I would like to hear opinions about the different format. Although the service of the meal left something to be desired, due to a hiccup in the kitchen (not literally!) I believe the day amounted to much more than a meal, and could well be the pattern for future functions. So please let us hear your views.

With best wishes for 1994.

Jon Croft.

OBITUARY.

ALLAN WILLIAM BOWRING, aged 51 years. A respected and caring member of the Brookton Community who had been on the land all his life and was a very successful farmer. Allan was a quiet, friendly, cheerful and happily married family man.

Allan and his three sons were foundation members of the Central Southern Group. They all enjoyed working with their hands and were talented wood turners. Our condolences to Rosemary, Rodney, Trevor and John and all of his family.

Dear Readers, Just to let you know the soft toy making by the ladies has been very successful again in 1993. We turned out some 420 soft toys. These were distributed to: Princess Margaret Hospital, Ronald McDonald House of Life, The Salvation Army and the Christmas Care project in Kalamunda. I would like to thank all of the ladies, for without them it could not have been done. Also many thanks to the members for turning out 140 wooden toys, well done boys.

Special thanks must go to D.I.M. Furniture Osborne Park, for kindly donating the filling for the toys. The cot raffle was also very successful and raised \$90 towards the ladies sewing kit.

Thanks again.

Elly K.

ASSOCIATION WEEKEND CALENDAR.

- Date: 19/20th February, 1994.
Venue: Tom Pearson Pavilion, Brunswick Junction.
Competition: Any item or items from 75 x 75 x 300mm
Host Group: Bunbury.
- Date: 19/20th March, 1994.
Venue: Loftus Community Centre, Cnr Loftus and Richmond Streets, Leederville.
Competition: Vase 400mm
Host Group: Melville.
- Date: 16/17th April, 1994.
Venue: Albany TAFE College, Main Road into Albany.
Competition: Matched pair of anything.
NO EMBELLISHMENTS.
Host Group: WAWA and Woodturners of Denmark jointly.
- Date: 21/22nd May, 1994.
Venue: Mandurah Senior High School. Mandurah.
Competition: To be advised.
Host Group: Mandurah.
- Date: 18/19th June, 1994.
Venue: Loftus Community Centre Leederville.
Competition: To be advised.
Host Group: North of the River.

DEMONSTRATIONS, EXHIBITIONS, SALES.

VICTORIA PARK Centenary Celebrations. Correction to telephone number published in Newsletter 49/93. The correct telephone number to contact DAVID CRANN is: (09) 362 4399.

Because of problems associated with dust etc, we have been advised that there will be no demonstrations in the shop. Members interested in sales and displays should contact DAVID CRANN.

26th March 1994 Brookton Old Time Motor Show, Brookton. Members wishing to participate, please contact NEIL BASDEN (09) 349 1082 or Ray BOWRA (09) 349 9310.

FOR SALE.

RTRTA (Atkins Carlyle) Heavy Cast Iron Lathe 12 years old. 3 Speed plus reverse switch. 1 metre long bed, 16" Swing. Craft Multi chuck. 14 Chisels. Books. \$800.
Please contact: Charles Gill (098) 8711 457

WORKSHOP MEETING 19/20th February, 1994.
Tom Pearson Pavilion, Showgrounds, Brunswick
Junction

The Bunbury Group welcome all WAWA members and their partners, friends and visitors to their workshop to be held in the Tom Pearson Pavilion in Brunswick. (Turn off the Southwest Highway at the Town Hall into Ridley Street.) This weekend will be run on a similar format to recent years. Convenor: Charlie Pizzino, MC: Taj Zaremba.

Competition: Any Item / Items from 75 x 75 x 300 mm.

Saturday 19th.

8 - 9.00 am Fellowship and registration.
 9 - 10.00 Talk on Electrical Safety.
 10 - 10.30 **MORNING TEA.** Members please bring a plate.
 10.30 - 11.30 Chainsaw Safety, Maintenance and Operation.
10.30 Ladies Talk on Homoeopathic Medicine.
 11.30 - 12 noon Demos various, 8 lathes.
 12.00 noon **LUNCH.** (Sausage Sizzle \$2.00 each)
 1 - 3.00 pm Blacksmith Tool Making etc. (Ryobi Precision Saw 10" Demo) and Lathes demos.
1.45 Ladies Visit to a Bird Park.
 2.00 Competition entries close, voting commences.
 3 - 3.30 **AFTERNOON TEA.**
 3.30 - 5.00 Hands On.
 5.00 Finish.
 6.00 **EVENING MEAL.** Beef on a Spit at the Brunswick Tavern.

Sunday 20th.

9 - 10.00 am Hands On, 8 Lathes.
 10.00 - 10.30 **MORNING TEA.**
 10.30 - 11.45 Demos various.
 11.00 Competition voting closes.
 11.45 Load Lathes.
 12 - 1.00 pm **LUNCH.** (Sausage Sizzle \$2.00 each)
 1.00 pm President's report and forum. Show and Tell. Competition results. Guess The Wood Competition.
 3.00 Clean up and finish.

ACCOMMODATION.

Brunswick Tavern. Phone (097) 261 032.
 Caravan Sites \$10 on W/ends. Rooms \$20 per head.
Brunswick Caravan Park. Phone (097) 291 009.
Leschenault Inlet Caravan Park. Phone (097) 971 095.
Evendom Bush Log Cabins, Burekup. Ph (097) 263 012
Harvey Wagon Wheels Motel. Phone (097) 291 408.
Home Stay. Contact Charlie Pizzino. (097) 311 034

WORKSHOP MEETING 19/20th March 1994.
Loftus Community Centre, Cnr Loftus and Richmond
Streets, LEEDERVILLE.

The Melville Group welcome all WAWA members and their partners, friends and visitors. We trust you will enjoy a rewarding weekend. Convenor: David Cassidy MC: To be advised. Hands On Instructors: Keith Johnson, Ron Goodson.

Competition Item: Vase, up to 400 mm.

Saturday 19th.

8.00 am Chuck wagons arrive, unload and deploy lathes and equipment.
 9.00 Registration and Fellowship.
 9.15 Marketing, selling and supplying turned articles.
 10.00 **MORNING TEA.** Please bring a plate.
10.30 Ladies. Health and Personal Development.
 10.30 Copy turning and/or modern lathes.
 11.30 * A new chuck - Keith Seaman.
 12.00 noon **LUNCH.**
 1.00 pm Turning fence posts and stumps.
 2.00 Competition entries close, voting commences.
 Address: Abrasives.
2.00 Ladies. New Reflexology (Update)
 2.30 Melville's wizard.
 3.30 Show and Tell.
 4.15 Decorations.
 5.00 Fellowship.
 6.00 **EVENING MEAL.** Smorgasbord of Healthy Plates.
 Entertainment to be arranged.

Sunday 20th.

9.15am * Rotary Chisels.
 10.00 **MORNING TEA.**
10.30 Ladies. Folk Art.
 10.30 Environmental wood finishes.
 11.00 Competition voting closes.
 11.30 * Hand Tool Preservation Society.
 12.00 **LUNCH.** Load lathes etc.
 1.00 pm Presidents Forum, Show and Tell, Competition Results and Guess the Wood, Ladies choice.
 3.00 Final Clean up. All hands please.

* These programme items may be subject to change.

Footnote: Special request that all foods for morning and afternoon teas and evening meal be "Healthy Plates".

**GENIUS IS 1% INSPIRATION AND 99%
 PERSPIRATION !**

**HARD WORK MAKES A GOOD IDEA
 POSSIBLE.**

COMPETITION BROOKTON NOVEMBER 93.

This was the last competition to count for overall points for the year. The entries came in thick and fast with six Beginners, nine Intermediate and seven Open. Twenty two lidded boxes and as usual, all beautifully different.

RESULTS.

- Beginners:** 1st Kingsley Richards
2nd Barrie Spencer
3rd Gerald Young
- Intermediate:** 1st Kevin Pritchard
2nd Neil Piper
3rd Robin Halbert
- Open:** 1st Alan France
2nd Ken Rex
3rd Bob Nichols

Congratulations to all entrants and thanks Brookton for a great weekend again.

COMPETITION, WIND-UP AND ANNUAL PRESENTATIONS DECEMBER 1993.

Mulberry Farm at Caversham was the venue chosen for our annual presentation lunch. A few hiccups were experienced (not due to the food), but on the whole the majority of the feed-back I have received has been encouraging about the venue and the changed format. The competition was "The best thing turned this year". We were treated to a wide selection of items with a total of twenty five entries, six in Beginners, eight in Intermediate and eleven in Open. The standard was excellent as always. Thanks to our judges who, after much hard work, awarded the following places:

- Beginners:** 1st GERALD YOUNG Sheoak and Pine Square Edged Bowl.
2nd BARRY SPENCER Jarrah Locomotive.
3rd DIG CONSTANT Jarrah Cakestand.
- Intermediate:** 1st BOB RICHARD Jarrah Pedestal.
2nd KEN LOCKE Jarrah Burl Platter.
3rd ROBIN HALBERT Red Gum Pomander.
- Open:** 1st ALAN FRANCE Jarrah and Aloes Lidded Bowl.
2nd VIV PAUST White Cedar Bowl.
3rd LEN NICHOLLS Sheoak Platter.

The winners of the annual awards for highest accumulated points in 1993 were as follows:

- Beginners:** 1st HENRY WALKER. 14 points.
2nd BARRY SPENCER. 12 points.
3rd ELAINE BOYD. 8 points.
- Intermediate:** 1st KEN LOCKE. 30 points.
2nd ROBIN HALBERT. 28 points.
3rd TED COTGROVE. 27 points.
- Open:** 1st ALAN FRANCE. 49 points.
2nd BOB NICHOLS. 39 points.
3rd VIV PAUST. 27 points.

Thanks to all competitors for making my job worthwhile and congratulations to all placegetters.

Eric Walker.

PEDESTAL PATTERNS.

During my demonstration on pedestal turning and construction at the Brookton weekend, I referred to patterns derived from an English publication. I could not remember the name but a number of members questioned me on the matter.

The title of the book is "MOULDINGS AND TURNED WOODWORK OF THE 16th, 17th and 18th CENTURIES". It has been described as a rich source of ideas and applications of turned woodwork and mouldings, all presented in full sized details and sections. I support this description.

I have previously seen this book at Angus and Robertson. From memory, the sale price was \$35/\$40. I borrowed a copy from my Council library. Put in a request at your library, but you will probably have to wait a while.

Milton Rundle.

Editor's Note: I made enquiries and this publication can be ordered through Angus and Robertson's city store. Delivery time is 5/6 weeks. Present cost is the Australian dollar equivalent of Stg 13.50. A deposit of \$10 is payable on any orders placed, with balance in full on delivery.

"NOTHING IN THE WORLD CAN TAKE THE PLACE OF PERSISTENCE. TALENT WILL NOT, NOTHING IS MORE COMMON THAN UNSUCCESSFUL MEN WITH TALENT. GENIUS WILL NOT; UNREWARDED GENIUS IS ALMOST A PROVERB. EDUCATION WILL NOT; THE WORLD IS FULL OF EDUCATED DERELICTS. PERSISTENCE AND DETERMINATION ALONE ARE OMNIPOTENT. THE SLOGAN "PRESS ON" HAS SOLVED AND ALWAYS WILL SOLVE THE PROBLEMS OF THE HUMAN RACE."

ACCOMMODATION, ALBANY WEEKEND.

- | | |
|-------------------------------|----------------------|
| Albany Tourist Bureau. | Phone: (098) 41 1088 |
| Emu Point Beach Chalets. | Phone: (098) 42 2666 |
| Emu Point Caravan Park. | Phone: (098) 44 1147 |
| Frenchmans Bay Caravan Park. | Phone: (098) 44 4015 |
| Happy Days Caravan Park. | Phone: (098) 44 3267 |
| Middleton Beach Caravan Park. | Phone: (098) 41 3593 |
| Mt Melville Caravan Park. | Phone: (098) 41 4616 |

and many, many more. Contact the Tourist Bureau for further information.

precision
WOODCRAFTS

CLOCK CRAFTS SUPPLIES
AND ACCESSORIES

Quality clock movements, weather
instruments, dials, numerals, musical
movements, pen funnels and LOTS MORE.

Also repairs.
MAIL ORDERS WELCOME



7 Wildwood Heights
Leeming, W.A. 6149
Tel: 09-3324481
Fax: 09-3326811

Wholly owned by Wagen Pty Ltd.
ACN 005 177 593

NEW PRODUCTS FEATURE ...

No articles on new woodturning/woodworking products were received from any of our advertisers for this issue.

ANNUAL ACCOUNTS.

At the annual general meeting in September, I undertook to arrange publication of the details of expenses and income relating to weekend workshops – and then I forgot. My apologies to all members for the delay in presenting the details published in this issue.

Milton Rundle. Treasurer.

WEEKEND WORKSHOPS 1992/93.

RECEIPTS.

Members Fees.	\$ 6268
Accommodation Denmark.	1653
Refunds. Bond hire	200
	\$ 8121
Less: Cash payments made.	1509
Receipts as per statement.	\$ 6612

PAYMENTS.

	Cash Book	Cash
Hall Hire.	\$ 3194	-
Accommodation Denmark.	1650	-
Refunds.	136	-
Name Badges.	128	-
Fees paid to Demonstrators.	480	-
Phone refunds.	106	-
Refreshments, trophies, door prizes.	143	1186
Stationery.	19	5
Christmas Cake.	65	-
Presentation Certificates.	244	-
Bus Hire.	125	-
Fees.	12	24
Postage.	9	117
Sundry.	—	177

Payments as per statement. \$ 6311
Payments made by cash. \$ 1509

STEPHEN HUGHES.

Western Australian turners have been fortunate over the last three weeks in having Stephen Hughes, one of Australia's leading turners and teachers of craft, conducting workshops and demonstrating.

Stephen was born in Melbourne in 1958 and grew up there having been educated at St Joseph's Primary and St Kevin's Secondary schools in Toorak. In 1980, he completed a four year Bachelor of Education at Melbourne State College. He majored in Woodcraft under the tuition of Vic Wood.

Stephen is a full time teacher, having started at Lavers Hill and presently at Karingal Secondary College in Frankston, Victoria. Despite his full time teaching commitments, he has found time to promote not only his own wood turning skills, but to assist in advancing the craft of woodturning in Australia and in the United States. His first exhibition was as part of a group in his final university year and his first solo exhibition was held in 1985 and was called "Decorative Woodware" and presented at the Craft Centre in Toorak.

Stephen is known world wide for his use of huon pine together with a combination of timbers such as jarrah, blackboy and sheoak. He also uses such other materials as beads, amber, stained glass, semi-precious stones, turquoise, jade etc. Latterly, Stephen has tended to concentrate on carving to enhance turned pieces in some of his major works.

Ninety five percent of his production is one off pieces of art varying in price from \$200 to \$30000. Fifteen major works have been sold in the USA and eight in Japan. This gives some indication of his reputation as a quality turner.

Other activities in his busy life include editor of the turning section of "Wood Review", judging at shows and demonstrating as he did at the World Turning Conference in Wilmington, Delaware, USA. While there, he also attended a symposium at Bucks Country and another at Brigham Young University, Salt Lake City, Utah which was organised by Dale Nash. He has been invited back to the United States to demonstrate at their Annual Conference this year.

This is Stephen's third trip to WA and he has conducted workshops at Midland, Denmark, Albany and Bunbury and also judging at the Denmark competition. For those fortunate enough to participate in these workshops the experience is invaluable.

Stephen is married to Mary and they have a daughter Ruby aged 11 months. They live on a 3/4 acre block in Mordiallac where Stephen has an excellent workshop attached and an adjoining shed to house an extensive collection of timbers including substantial quantities of his beloved huon pine.

All West Australian turners thank Stephen for the time spent here, for his enthusiasm and great teaching ability. They also wish him well in his future endeavours.

Robin Halbert.

GOD DOESN'T LOOK AT HOW MUCH WE

DO, BUT WITH HOW MUCH LOVE

WE DO IT. Mother Teresa (1910 -).

COMING EVENTS

MEN OF THE TREES will be holding their annual field day on Saturday, 9th April, 1994 at "St Barbe Grove", Lot 2 Stirling Crescent, Hazelmere.

This year the theme will be:

LIVING SOIL IT'S UP TO ALL OF US

There will be lots of childrens activities, theatre and music around the theme as well as a series of short lecturettes and demonstrations.

WAWA are invited to set up a stall to disseminate information and/or sell turned articles.

GOLDFIELDS SPECIALTY TIMBER INDUSTRY GROUP Inc.

plans to hold several field trips involving botanical identification, timber collecting and exploration of new areas. Planning has commenced for a two day trip (overnight) to the Johnson Lakes from Coolgardie returning via the Norseman-Hyden Road.

Date: Anzac Long Weekend Saturday 23rd April to Monday 25th April, 1994.

Plan: Field Trip Saturday 23rd and Sunday 24th April.

A day in Kalgoorlie-Boulder Monday 25th April for processing timber and samples. Also for visitors to view GSTIG activities and developments.

An invitation is extended to anyone who is interested in the field trip and/or day in Kalgoorlie-Boulder. All participants would need to be self contained. Roads are suitable for 2wd unless there is heavy rain.

If interested, please let GSTIG know and as more details are organised, you'll be kept informed.

Contact: Post Office Box 366 Kalgoorlie 6430
Phone: (090) 212677
Fax: (090) 217831

MEDIA RELEASE

SOLAR TIMBER KILN CONSTRUCTED IN KALGOORLIE-BOULDER.

Kalgoorlie-Boulder's developing specialty timber industry has received a boost with the construction by Timbers of the Goldfields owner Phil Panton, in co-operation with CALM and GSTIG, of a solar timber drying kiln.

The kiln was constructed with a \$25000 grant, approved under the Federal Government's Renewable Energy Research Program, by Simon Crean, the Minister for Primary Industries and Energy. The grant was obtained with the assistance of Kalgoorlie Federal Member Graeme Campbell.

The award winning solar kiln technology was developed by the Department of Conservation and Land Management at the Harvey Wood Utilisation Research Centre (HWURC). It is now commercially available and being installed at various timber producing locations throughout Australia.

The solar kiln technology has been demonstrated and proven in the South West of WA where it has been shown to be very cost and energy efficient for small sawmillers. Construction of the kiln in Kalgoorlie-Boulder will permit research to be extended into a semi-arid, more solar efficient area and permit essential seasoning research on Goldfields timbers.

A research project involving Phil Panton, GSTIG, CALM, GEDA and the Kalgoorlie College is being developed. The research will involve seasoning of Goldfields timbers using the kiln, running the kiln, monitoring results and basic timber properties research on a range of Goldfields timber species. The kiln will be automatic, computer run and continually monitored with constant automatic recording of climate so results can be published in the future.

Background. For several years the Goldfields regional office of CALM has been promoting the development of a specialty timber industry for the Goldfields. This potential industry would be based on resource from the extensive regrowth and uncut Eucalypt woodlands surrounding Kalgoorlie-Boulder and the wide range of unique timbers available from throughout the pastoral and desert areas.

Results from a range of ongoing research and trials have been encouraging and this led to the formation of the GSTIG Inc. with the aim of further promotion and development of an industry.

Construction of the solar kiln allows the specialty timber industry to progress to the next phase, which is to overcome timber seasoning and processing problems. Once further research and development has solved some of the unique local timber seasoning problems, the industry has potential to scale upwards using the kiln in a commercial sense to provide a reliable, seasoned, marketable product.

Moisture in timber is a major problem, especially in Goldfields timbers which are difficult to dry without splitting. To minimise the splitting, timber has to dry very slowly.

To solve problems and speed up drying, CALM developed the new solar powered wood drying system. The kiln has a double shell of soft, inflatable, UV-resistant plastic. This forms an insulated solar collector. The controlled air inside can be separately heated and humidified according to the needs of the timber at different stages of drying. Large fans blow air through and around the stacks of timber, drying them evenly.

The stacks are covered by a patented blanket, and by adjusting the fans, the curtain filters, or fogger water sprays, any splitting or checking can be minimised. The wood can be inspected at any time simply by unfastening the Velcro-sealed door and stepping inside. And the heat comes from the sun - free !!

This innovative system dries wood cheaply, quickly and evenly, and even the smallest sawmill can afford it.

Our thanks to Ian Kealley for this article.

SANDING TABLE.

Alan France.

This is an easy to make and accurate performing sanding table to add to your lathe accessories. The dimensions given suit a Woodfast lathe, but could be modified to your machine.

Requirements. 180 x 50 x 50 jarrah (or any hardwood)
 100 x 110 x 16 M.D.F.
 38 x 10 gauge c/sunk head woodscrew.

- Procedure.**
1. Drill a 5mm (13/64") hole through the centre of the M.D.F. and c/sink to suit head of the woodscrew.
 2. Mount the jarrah piece between centres and turn a spindle 135 long x 25 dia. This should be a neat fit in the toolrest post.
 3. Produce a **flat** or **slightly concave** end on the remaining 50 x 50 part.
 4. Drill a 3.5mm (9/64") hole 40 deep on the same end. (I use a nova chuck to hold the spindle end to drill in the lathe).
 5. Screw the parts together.

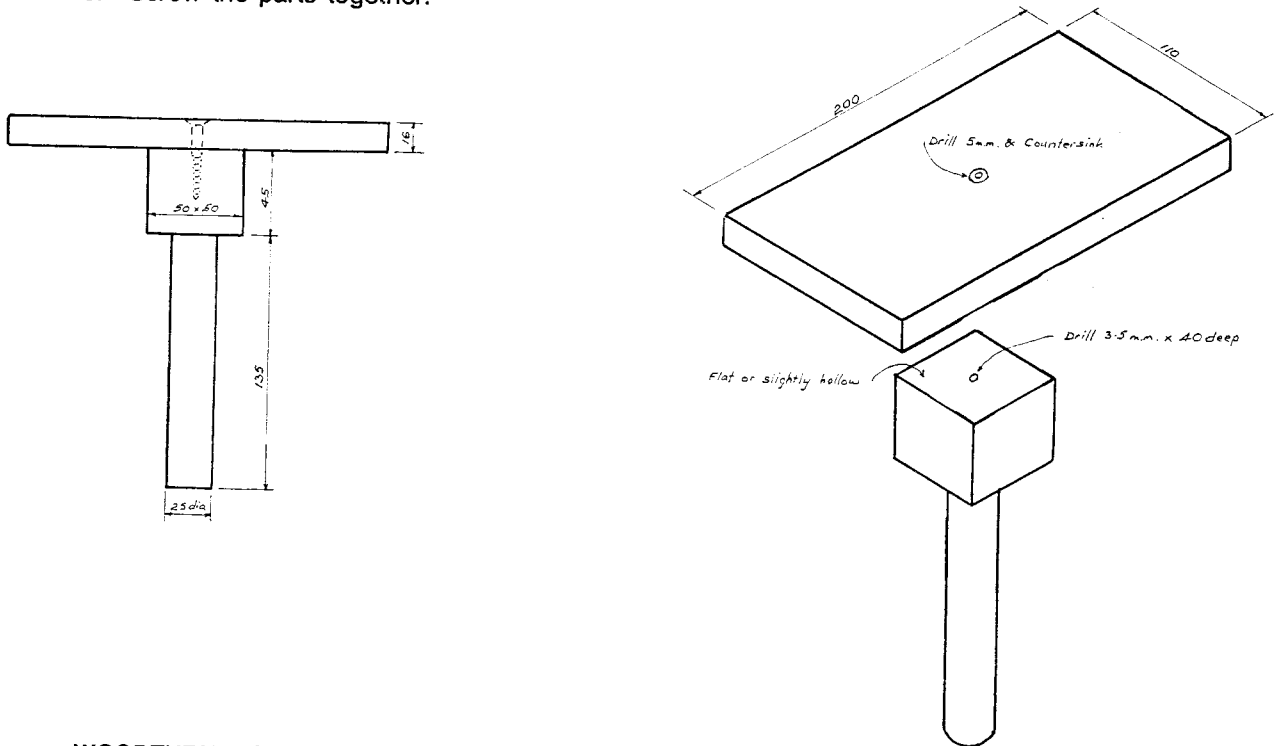

WOODTURNERS ASSOCIATION OF W.A. (INC.) Committee and Convenors 1993/94

PRESIDENT. Jon Croft Phone: 09 527 8048	VICE PRESIDENT. Len Nicholls Phone: 09 339 6490	SECRETARY. Neil Basden Phone: 09 349 1082	TREASURER. Milton Rundle Phone: 09 385 9559	PAST PRESIDENT. Cyril Jones Phone: 097 55 3606
--	--	--	--	---

COMMITTEE.

Max Hayles	(W/end W/Shop)	09 349 4125
Neil Piper	(Video Library)	09 398 2387
Ray Bowra	(Shop/C Shows)	09 349 9310
Jim Waters	(Safety)	09 446 1641
Russ Russell		09 337 7631
Les Small		09 364 6143

OFFICE HOLDERS.

Dig Constant.	(Property)	09 349 7637
---------------	------------	-------------

CONVENORS.

AVON VALLEY.	Glyn Harrington.	09 574 2129
BUNBURY.	Charles Pizzino.	097 31 1034
BUSSELTON.	Ray Batt.	097 52 1351
C / MIDLANDS.	Keith Lenane.	096 51 4133
C / SOUTHERN.	Jeff Nottle.	096 42 7024
COLLIE.	John Wallace.	097 34 1209
KENWICK.	Gerald Young.	09 399 5002
MANDURAH.	Ray Quadrio.	09 535 2755
MELVILLE.	David Cassidy	09 451 5701
MIDVALE.	Ken Locke.	09 299 7370
MUNDARING.	John Dillon.	09 299 7125
NORTH OF RIVER.	Ron Ahrens.	09 447 9214
TOM PRICE.		

MEMBERSHIP(Reg.)

Cheryl Russell
 19 Mopsa Way
 Coolbellup. 6163
 Phone: 09 337 7631

EDITOR

Robin Halbert
 PO Box 941
 West Perth. 6872
 Phone: 09 322 2633
 Fax: 09 321 1172

**PEOPLE WHO NEVER CHANGE THEIR MINDS
 ARE EITHER PERFECT OR STUBBORN !!**

WOODSTOCK

Timber Tools & Hardware PTY LTD

TIMBER

PINE

JARRAH
TAS OAK
SHEOAK
WANDOO
TUART
POPLAR
ASH
WALNUT
CHERRY
JELUTONG

MAHOGANY
TEAK
AM RED & WHITE OAK
EBONY
BLACKWOOD
MALAY KAURI
NYATOH
MERANTI
W.R. CEDAR
OREGON

201 Balcatta Road,
Balcatta, W.A. 6021
Phone: (09) 345 4522
Fax: (09) 240 1014

LATHES TOOLS

SAWS

JAPANESE TOOLS
SINGLEY DRUM SANDERS
SHARPENING STONES

WOODTURNING TOOLS
WOODCARVING
SPOKESHAVES
PLANES

10 JOHN STREET
BENTLEY 6102
PHONE 356 1653
FAX 321 4200

CRAFT ACCESSORIES



Willetton Hardware

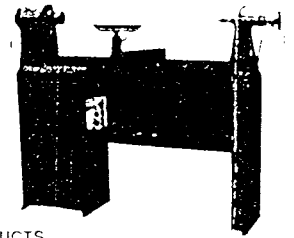

PRODUCTS

Makita power tools, Triton work centre, Tough lathes, band saws, finishes, Woodlast lathes, clock movements, Sorby woodturning chisels, cutlery blanks, P&N woodturning chisels, barometers, thermometers, hygrometers.

SERVICES

Saw and tool sharpening, key cutting. Open 7 days per week

CONTACT Philip R. Knowles

PHONE (09) 457 8323

ADDRESS 3/9 August St, Willetton WA 6155

W.A.'s



WOODTURNING CENTRES



CROSS ELECTRICAL SUPPLIES
90 BLAIR STREET, BUNBURY
PHONE (097) 21 5858

THE WOODWORKING CENTRE
14 STANHOPE GARDENS, MIDLAND
PHONE (09) 274 5655

ALL YOUR NEEDS FOR:

LEISURE ACTIVITIES WITH WOOD

WOOD LATHES: Tough, Woodfast, Teknatool, Durden, Vicmark
WE HAVE:

THE EQUIPMENT AND ASSOCIATED CRAFT ACCESSORIES
CHISELS, BOOKS, VHS TAPES AND CAN ORGANISE YOUR LESSONS

W.A. TRADE TOOL CENTRE

UNIT 1 - 10 Pitt Way, Myaree.

(09) 330 3399

FOR ALL WOODTURNING SUPPLIES

SELECTION OF LATHES • BANDSAWS • SCROLLSAWS • BENCH
GRINDERS • SORBY TURNING TOOLS • PFEIL CARVING
TOOLS • LACQUERS & FINISHES • ENVIROTEX • CLOCK
MOVEMENTS • LAMP FITTINGS AND VARIOUS ACCESSORIES
ALSO SALES AND SERVICE FOR MOST MAJOR BRANDS OF
POWER TOOLS



SHARP TOOL SERVICE

- WOODFAST Lathes • Planers - Thicknessers - Sanders
- LEIGH Dovetail jigs • FREUD, RAPIER, AUSTSAW, Sawblades
- BORMAC Bandsaws • BANDSAW Blades made to size
- RYOBI, MAKITA Power tools • P & N Turning chisels
- CARBA-TEC Router bits • HEGNER Scroll saws
- FEAST WATSON Timber finish & stains
- Gift Vouchers • Hobbycraft Books
- SAW DOCTOR - Industrial, Hobbyist, Gardeners

25 Gympie Way
WILLETTON W.A. 6155

Phone: (09) 457 7826
FAX: (09) 354 3318



WOODTURNING & SUPPLIES

Supplying Woodies with the Goodies

Wood turning blanks
from recycled Jarrah.
Turning Chisels Carving Chisels
Clock Movements
Polishes and Sand Papers

TREVOR FIELDING

Unit 3, Savery Way,
Rockingham, 6168

592 2293

ROTARY CHISEL

- THE CHISEL WITH THE EDGE -

- CUT GRIND SHAPE WOOD
- TUNGSTEN CARBIDE TEETH
- FAST SHAPING AND CUTTING
- OUTSTANDING FINISH
- SMOOTH AND PREDICTABLE
- GUARD ENSURES USER SAFETY

PH/FAX 097 91 1643
P. O. BOX 1095 BUNBURY WA 6230

T-Gem Wood Lathes

Australian Made
3 Std sizes or to order

10" x 30" bc Live Centre, Camlocks
16" x 36" bc Hollow Tailstock
18" x 48" bc Indexing, No2 Morse

Barnwell Engineering Developments
5/2, James Street, BAYSWATER,
W. A. 6053 Ph or Fax (09) 272 8033