

The Official Newsletter of the

THE WOODTURNERS

ASSOCIATION OF WESTERN AUSTRALIA INC

NUMBER 31

DECEMBER 90

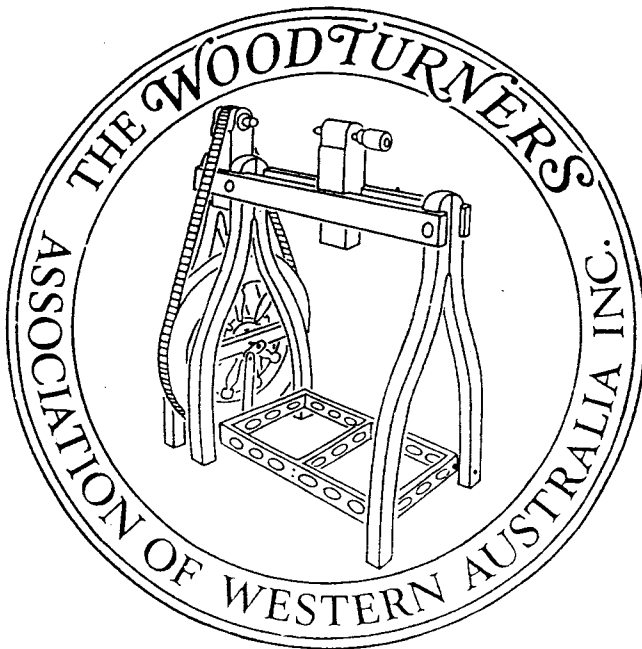

REGISTERED BY AUSTRALIA POST. PUBLICATION N° WBG 1883

MANAGEMENT COMMITTEE:

PRESIDENT:

Cyril Jones
6 Burt Court
Dunsborough 6156
097 553606

SECRETARY:

Nancy Launer
Unit 7
Busselton Gardens
Busselton 6280
097 523998

TREASURER:

Milton Rundle
26 Norbury Crescent
City Beach 6015
(W) 09 2653263
(H) 09 3859559

EDITOR:

Geoff Barkla
P.O. Box 115
Kalamunda 6076
09 2934330

ASST. EDITOR:

Ivor Bridges
4 Grancy Avenue
Mundaring 6073
09 2951867

COMMITTEE:

Bob Richards
83 Glenig Avenue
Wembley Downs 6019
09 341 3235

COMMITTEE:

John Lathwell
22 Mary Drive
Lesmurdie 6076
09 2916280

COMMITTEE:

Gordon Ward
23 Hill Street
Kelmescott 6111
09 3906418

COMMITTEE:

Bob Adams
P.O. Box 2
Coorow 6515
099 523234

COMMITTEE:

Jim Clarke
7 Peter Road
High Wycombe 6057
09 4545337

COMMITTEE:

Brian Launer
Unit 7 Busselton Gardens
Busselton 6280
097 523998

MEMBERSHIP:**SECRETARY**

Cheryl Russell
19 Mopsa Way
Coolbellup 6163
09 3377631

PROPERTY:

Digger Constant
10 Clearview Avenue
Mt. Yokine 6060
09 3497637

VIDEO LIBRARIAN:

Keith Stout
20 Currajong Road
Duncraig 6023
09 4482632

Alan Banton
Boys 8
Birdie Bunt
65724

CANCELLATION OF A MEETING:

Melville Group advise their normal December Meeting has been cancelled. January meeting will be as normal.

ASSOCIATION WEEKEND CALENDAR:**DATE:**

December 8th
January 19-20th 1991
February 16-17th
March

VENUE:

Belmont
Leederville
Brunswick

COMPETITION:

Best thing made this year.
Bedside Lamps - advanced pair - Open pair - Novice 1
Anything turned from wood
Candle stick holder. Strict dimension diagram to be printed in February newsletter.

PRESIDENT'S REPORT:

No doubt some noticed a change in the last newsletter. Immediate Past President Geoff has taken over the reigns as The Editor of our newsletter. Many thanks Geoff.

I know you will all join me in expressing a sincere thank you to Ivor for the excellent job he has done over the past 5 years. In saying thank you to Ivor, we cannot forget the support he has received from Sherri. I know you have both put a lot into the production, chasing material, people, printers, etc., to ensure the newsletter gets out on time. It has been quite a task, so ably carried out.

I would also say thankyou to Bob Richards who has accepted the position as Vice President of The Association, and I know he has a lot to offer.

John Lathwell has accepted the position of Chairman of our Weekend Workshop Programme Planning Committee with Gordon Ward and Bob Adams assisting him. Members, please if you have any suggestions regarding future meetings I am sure John, Gordon and Bob will be keen to talk to you.

During the year we have had some very good weekend workshops, and it is worth noting that generally we have had approximately 20% more members and partners attending each weekend than we had at the respective venues last year.

This year we have had a number of visiting speakers and demonstrators to our workshops. No doubt the 3 days Stephen Hughes spent with us at Bunbury, Midvale and Wanneroo will be long remembered and already his influence has been evident in some work done by various members.

Visitors are always welcome. Bob and Jean Morehead from New Mexico were with us for a few workshops and I know made a number of friends. Elsewhere in the newsletter is a letter from Bob and Jean.

Clare joins me in wishing all our members and their families a Happy Christmas and may 1991 be a year of peaceful solutions throughout our troubled world.

We look forward to seeing as many as can attend our Christmas function at Belmont.

Cyril

UNFINANCIAL MEMBERS are reminded that unless they renew their membership before the 31st December 1990 their name will be struck off the register. Please make your cheque to: - Woodturners Association W.A.
Post to: - Membership Secretary
19 Mopsa Way, COOLBELLUP 6163

NOTICE TO ALL MEMBERS, ASSOCIATES AND VISITORS.
SAFETY ADVISORS ADVICE MUST BE ADHERED TO AT ALL TIMES.
MANAGEMENT COMMITTEE.

THE WOODTURNERS ASSOCIATION OF W.A. WORKSHOP/MEETING:

Saturday **ONLY** 8th December 1990.

At the Australian Agricultural Machinery Premises, 37 Abernethy Road, Belmont.

Welcome to our 'Christmas Event' - all W.A.W.A. members spouses and visitors to our fun and prize giving day.

Your host - Executive Committee

Convenor - John Lathwell M.C. - Gordon Ward

Hosts and lathes supervisors - Committee Members

Safety Advisor - Gordon Ratcliffe

Trade Supplier - Hammersley Hardware

PROGRAMME:

8.00 Chuck Wagon —————lathes arrive

9.00 Registration and fellowship

Competition set-up - Bill Botman

'Best thing you have made' - final entry 12.00 noon. Prize & plaque

'Toy Exhibition' (hand made) - final entry 12.00 noon prize.

LADIES: "Ladies Exhibition for all to see" examples of work completed or inspired by ladies activities/demonstrations of the past year - prize.

9.55 President's announcements

10.00 MORNING TEA

10.30 Pyrography demonstration by Steve Makin (all day)

10.30 Two 'Turning Competitions' both competitions will run simultaneously all day.

A. 'Hand spun top' B. 'Dibble'

Both - design your choice, two tools of your choice, finish off tool - no sand paper. Ladies to judge - prizes Association tool available.

12.00 LUNCH B.Y.O.

1.00 Competitions continue

2.30 AFTERNOON TEA

3.00 Competitions continue

4.30 Top & Dibble prizes given

4.45 Load Lathes

5.00 EVENING MEAL Members to supply mixed salads. Association supplying meat & dessert

6.00 Announcement of competition winners and awards

6.30 Guest Speaker - Peter Hartland on 'Marionettes'

Note! Competition winners and awards are the accumulation of points during the year.

TOUGH'S CHRISTMAS SALE SPECIAL

Prices of all Tough's products will be reduced by 12¹/₂% for a period of 2 months from 1st December until 31st January 1991.

This offer is not available to resellers.

Make use of this special offer.

Super Specials 1" Cup Chuck Small Taper Bore \$25.00

WEEKEND LOFTUS STREET, LEEDERVILLE SEPTEMBER 15/16:

The President's report published in the October No. 30 Newsletter covers most things. The Auditor's report and the Annual Accounts were received and adopted. The returning Officer Mr. R. Leggo declared the following nominations:-

PRESIDENT: Mr. C. Jones

COMMITTEE: Mrs. N. Launer, Mr. J. Clark, Mr. B. Richards, Mr. J. Lathwell, Mr. B. Launer, Mr. M. Rundle.

The following resolutions were passed: -

Nomination fee for 1990/91 be \$20.00.

Membership Annual fee for 1990/91 be \$15.00

A sincere welcome back was extended to Edgar Lewis who was visiting us after many months on the sick list. He thanked everyone in W.A.W.A., for their good wishes with a special thank you to those who cheered him up with visits while in hospital.



BUSSELTON

Most of we city folk used this week-end as a lovely "week-end away" and enjoyed ourselves immensely. The weather was kind and Busselton turned on a floral face for we ladies at least. However, some of us ended up at the Old Court House and visited the prison cells. I do not think it was "kind" of those who said "I was lucky to be allowed out!"

Now down to the nitty gritty! The competition was a Nut Bowl and Cracker. Ladies choice went to Keith Seaman. In the Open B. Launer's entry was the only one but lovely lovely. Novice were 1st - Ray Batt, 2nd - Geoff Wood and 3rd - Elaine Boyd.

What wood is that ? won by Gordon Weatherall.

The door prize won by Gay Barkla Lucky girl!

The Show & Tell was taken by Bob Adams who called upon Tony Milson, Brian Launer, Don Keynes, Bob Simmons, Gordon Ward, Bert Nicholls, John Shinbock, Ron Smith, Tom Kettle, Adnan Broad & Harry Norman to talk about their interesting and beautiful articles. As I've said before this is an excellent part of the week-end and very intriguing to hear about "how, when, where and why" the pieces were turned.

We had an extremely nice evening meal and the ladies were thanked very much for their catering efforts over the two days.

Saturday evening we had a fascinating lecture by Mr. J. Thorpe (Chief Guide Yallingup Cave). It was much appreciated by all. It inspired many to go and have another visit to this wonderful underground world.

Thora.



A SAFETY WARNING:

About a year ago metal sanding plates were recommended to me for sanding turnings. There are good reasons for this as they are quite effective and last well. Late one evening (about 10pm) I was sanding the inside of a shallow bowl, and what happened next was so fast that I can only speculate on the sequence of events. The result however was very clear and it was a nasty gash to my thumb requiring four stitches. There has been some nerve damage but it could have been a lot worse. I will never use these plates again on rotating wood. May I suggest that if you also sand with these plates either think again, take great care, or for the foolhardy, check your medical insurance. They are potentially very dangerous.

Anonymous

WORKSHOP MEETING:

FEBRUARY 16th & 17th 1991 at TOM PEARSON PAVILION. BRUNSWICK SHOW GROUNDS:

Starts 9.00am Saturday.

The usual 'hands on' and demos plus mini lathes (anyone able to bring one along will be most welcome)

John Lathwell will be available to print our Logo on Aprons & Teeshirts.

Demos for Ladies. Easy punch embroidery Saturday 11 am, using hand held machine which walks across the cloth (really worth seeing says John Shinnick)

Saturday 1 pm Visit to Deer, Trout and Marron Farm Wokalup. 2 hours approx.

Tea Saturday Evening. On again! 'Beef on Spit' and salads \$6.00 per head at Brunswick Tavern. Please pay for seats Saturday morning at registration table.

Accommodation - Brunswick Tavern: Phone: 197 261032 Cost per night \$30 double. \$40 twin. \$20 single. Breakfast \$7.50

Brunswick Caravan Park - same phone 097 261032 \$8 head (powered and unpowered sites)

Leschenault Inlet Caravan Park - Phone: 097 97195 \$9 head less discount

Scenic Drive Australind - Wagon Wheels Motel phone 097 291408 Harvey \$40 single \$50 double

GUESS THE WOOD COMPETITION - BUSSELTON:

Wood Quandong Location Wheat belt Brookton area. Age not known very old. Cut May 1990 Turned September 1990. Finish Estapol 7008 50% with thinners. Supplied by Bert Simmons

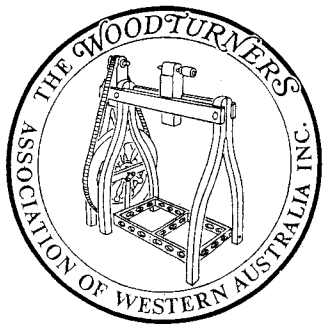

Motto

**WHILE I GROW
LET ME LIVE
WHEN I DIE
MORE PLEASURE GIVE.**

Objects

**TO PROMOTE THE ART OF WOODTURNING.
TO BE CONSERVATION CONSCIOUS IN USING
RECYCLED TIMBER, WASTE FOREST PRODUCTS
AND WASTE DOMESTIC TREES, FRUIT AND
EXOTICS FROM RESIDENCES.**

FOR SALE:

8 x 2 litre Mirothane Lacquer 100% @ \$4.12 per litre

8 x 2 litre Thinners @ \$2.84 per litre

Phone: 09 332 3023 - N. Piper 285

GROUPS WHEN & WHERE THEY MEET:

GROUP:	WHERE:	WHEN AND PHONE:
Kenwick	Lidlow Homestead	1st & 3rd Wednesday 459 5702 390 7724
Mundaring	Westrack Stoneville	Every Friday 295 2043
North of the River	Girrawheen Rec. Centre Hainsworth Avenue	2nd Wednesday 349 1082 275 2765
Midvale	Woodworking Centre Stanhope Gardens, Midvale	1st Friday 295 2281 296 4912
Melville	Palmyra Rec. Centre Cr. Murray Rd. & Canning Hwy.	4th Thursday 339 2409 332 4147
Central Southern	Brookton School	2nd & 4th Wednesday 098 871 4571 906 42 1167 096 42 7024
Bunbury	Cross Electrics Bunbury	1st Wednesday & 3rd Friday 097 26 1020
Busselton	Senior High School	1st & 3rd Wednesday 097 52 3998 097 55 3606
Mandurah	Senior High School	Alternate Tuesdays 535 1130 535 3980 535 2755
Collie	Meet at Members Homes	Contact J. Wallace 097 34 1209
Merredin	High School	3rd Tuesday 090 41 1107 090 44 1064
Central Midlands	Moora	099 52 3234

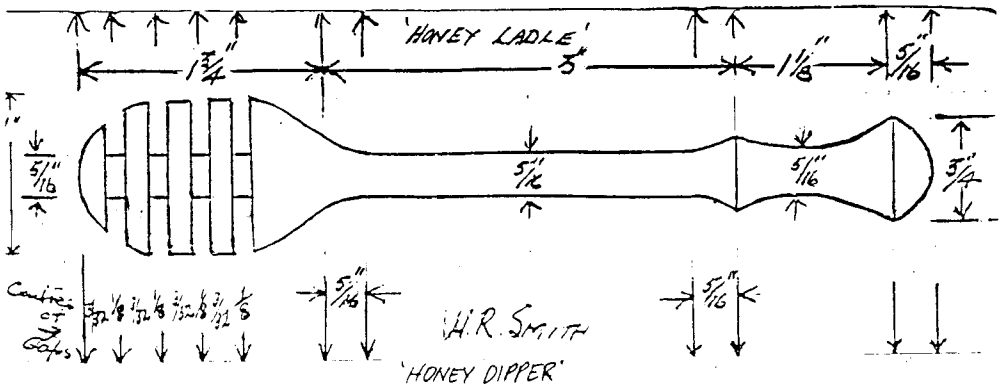

ROSE BOWL:

Bert Simmons from Brookton submitted the following interesting project. Thank you for this Bert, we are always on the lookout for new and different projects. Bert writes 'I have made and found the design attractive and functional. I used Estapol 7008 two pot clear finish 3-4 coats depending on porosity of wood used, each mix of Estapol thinned with Estapol thinners No. 7008 equal part mix with equal part thinners which gives very good penetration and a good smooth finish when brushed on, and is water proof, follow instructions re thinning carefully. NOTE: This finish will waterproof bowl both inside and outside.

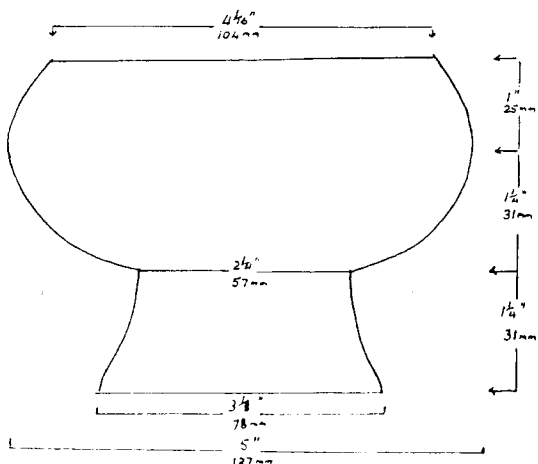

Use Oasis Foam to hold flowers inside bowl.

A 'TOUGH' MAN:

My lathe is a **TOUGH** bought about six years ago, I have no regrets about my purchase. It has served me well. It's basic features are - four speeds, three feet between centres, cast iron stepped bed which allows 16" diameter turning for three inches from the driving centre and 12" diameter over the remainder. The driving centre is hollow and threaded externally 1" by 10 T.P.I. and with a left handed thread on the outboard side of the lathe.

For the type of turning I do, often involving out of balance blocks of timber, the rigidity and weight of the **TOUGH** is an essential feature. My lathe is not fixed to the floor and the self weight is necessary to reduce vibration. On occasion I would like the slowest speed (RPM unknown) to be a bit slower when dealing with a particularly extravagantly piece of mallee root, but this may well impose a safety limit on what I may try.

As supplied the lathe did not have a live tailstock centre (since fitted) and the tool rest is not fitted with a cam lock. The current models do have these features but otherwise appear to be much the same (apart from the considerable increase in price)

Both the driving and the driven centres have a No 2 Morse taper internally so a suitable drill chuck may be fitted at either end if required. The travel on the tailstock is 2 7/8". The lathe was not fitted with a motor as supplied and I fitted a half horse power motor directly below the stepped drive pulley. The motor is not mounted on a hinged platform, speed changes are made by slipping the driving belt from one pair of pulleys to the next.

W.A. WOODTURNERS.
VIDEO TAPES AVAILABLE EX VIDEO LIBRARY.

WOODMILL SERIES

Lathe safety & spindle turning cup chuck & tool sharpening Wattyf finishing & Woodcraft Design.

DENNIS WHITE TAPES

Turning Bowls

Boxes Goblets & screw threads.

Spindle Turning plus Boxes Goblets, etc.

Turning Wood with Richard Raffan

Bowl Turning by Dell Stubbs

Wood Finishing - Frank Klaus

Chainsaws & Commonsense - Stihl

Bunnings Forest Products Dry Jarrah

Pure Enjoyment - Fine Woodworkers

Open Weekend - Fine Woodworkers

Wax Finishing - Keith Johnson

Doughnut Turning - Viv Paust

Brunswick Meeting - Mike Darlow - W.A.W.A.

FOR LOAN OF TAPES CONTACT: -

KEITH STOUT, 20 Currajong Road, Duncraig. Phone: 448 2632

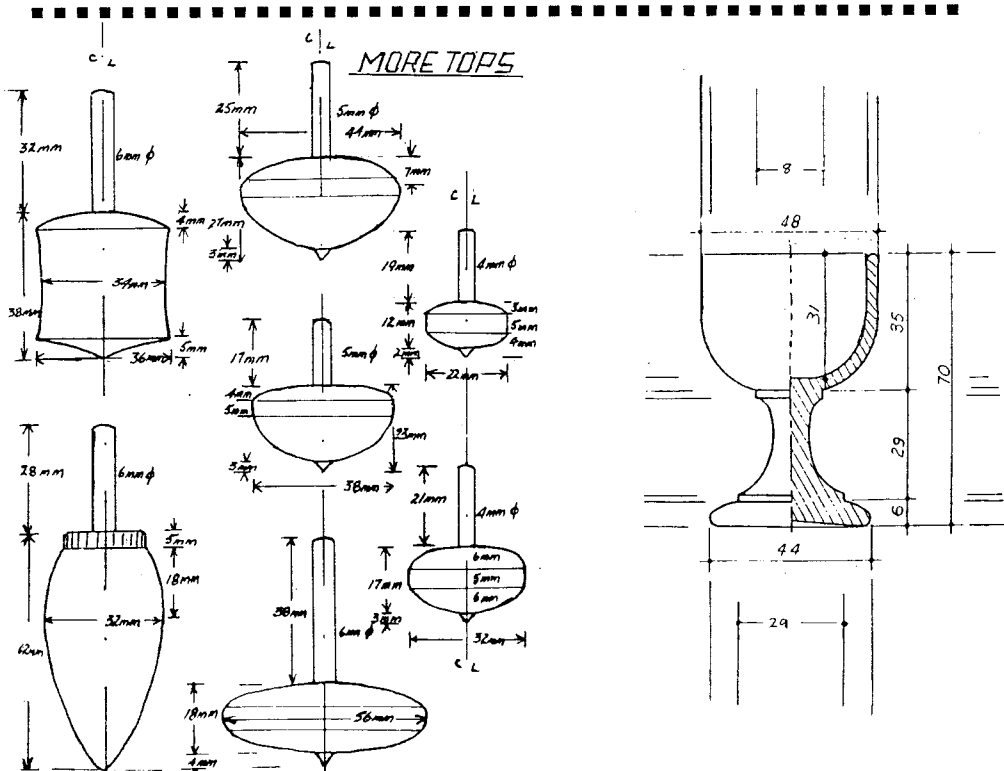

WOODSTOCK

TIMBER
TOOLS &
HARDWARE
PTY LTD

- SPECIALITY TIMBER, PLANS, BOOKS, HERMLE
- P & N, SORBY, MARPLES, PFEIL, DA STRA
- WOODFAST, T-GEM, TEKNATOOL, DURDEN
- ECLIPSE, SANDVIK, STANLEY, FOOTPRINT
- ARBORTEC, DEADRIGHT CLAMPS, IRWIN SPEEDBOR
- CARBA-TEC, DREMEL, SINGLEY, CONOVER, CLICO
- JAPANESE TOOLS, WETSTONES, HALLS ARKANSAS
- FULLER, DAVIS, FLEXOVIT, RUSTINS, WOLFCRAFT

201 Balcatta Rd, Balcatta 6021. 345 4522



*Robert
Sorby*

W.A.'s



WOODTURNING CENTRES



CROSS ELECTRICAL SUPPLIES

90 BLAIR STREET, BUNBURY

PHONE (097) 21 5858

THE WOODWORKING CENTRE

14 STANHOPE GARDENS, MIDLAND

PHONE (09) 274 5655

ALL YOUR NEEDS FOR:

LEISURE ACTIVITIES WITH WOOD

WOOD LATHES: Tough, Woodfast, Teknatool, Durden, Vicmark

WE HAVE:

THE EQUIPMENT AND ASSOCIATED CRAFT ACCESSORIES
CHISELS, BOOKS, VHS TAPES AND CAN ORGANISE YOUR LESSONS

W.A. TRADE TOOL CENTRE

UNIT 2, 8 PITT WAY, MYAREE

330 3137

FOR ALL WOODTURNING SUPPLIES

SELECTION OF LATHES • BANDSAWS • SCROLLSAWS • BENCH
GRINDERS • SORBY TURNING TOOLS • PFEIL CARVING
TOOLS • LACQUERS & FINISHES • ENVIROTEX • CLOCK
MOVEMENTS • LAMP FITTINGS AND VARIOUS ACCESSORIES
ALSO SALES AND SERVICE FOR MOST MAJOR BRANDS OF
POWER TOOLS

OPEN 7 DAYS

" NEW " Mail Order Service

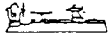

Tough, Woodfast Lathes

Sorby Wood Turning Tools, Richard Raffin, Woodfast, Sorby Chucks. Electrical Fittings, Thermometers, Barometers Cutlery Blanks, Clock Movements, Finishes

WILLETTON HARDWARE

3/9 Augusta Street, Willetton, W.A. 6155

457 8323

10% DISC
V.A. V.A. Members (Specials Excluded)

HAMERSLEY HARDWARE AND WOOD TURNING TOOL SUPPLIES

Tough, T/Gem	Mirothane
Woodfast	Mirowax, K36
Tekney Lathes	Shellac
Band Saws	Bees wax
P & N H/Taylor	Aqua putty
H/S Tools	1/2 & 5/8 Chucks
Grinders & Stones	No.2 Morse Tapers
Long Series Drills	

75 Eglinton Crescent
Hamersley W.A. 6022
Telephone: 448 1667

T-GEM T-GEM T-GEM T-GEM T-GEM

T-GEM

T-GEM

T-GEM

T-GEM

T-GEM

T-GEM

WOODWORKING LATHES BUILT TO DO THE JOB

Two models available.

Max Dia. over bed 406 457 4 speeds 500 1000 1700 3500
Max Dia. outboard 660 760 Live centre, Hollow tail stock
Between centres 914 1219 No. 2 Morse Tapers

BARNWELL ENGINEERING DEVELOPMENTS

Unit 5, 2 James Street, Bayswater
Western Australia 6053

Phone: (09) 272 8033 for details



T-GEM T-GEM T-GEM T-GEM T-GEM

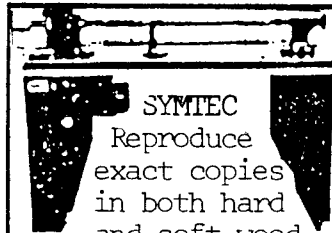

SYMTEC
Reproduce exact copies in both hard and soft wood

ALSO IN STOCK
TOUGH WOODFAST DURDEN LATHES

Call in for a hands on demo of the unique Symtec

HUGH W. BROWN (AUSTRALIA)

1301 ALBANY HWY. CANNINGTON
WESTERN AUSTRALIA 6107
TELEPHONE 458 4488



CHAIN SAWS

Discount Prices
FOR CLUB MEMBERS

**Bassendean
Lawnmower &
Chainsaw Centre**
95-97 Old Perth Rd., Bassendean
Phone 279 3668

THE WOODTURNERS

ASSOCIATION OF WESTERN AUSTRALIA INC

TOUGH
TEL (09) 277 1166

The Ultimate in Professional Wood Turning Lathes

2 MODELS ILLUSTRATED
HEAVY IRON CASTINGS
FOUR SPEEDS - V BELT
OUTBOARD TURNING
36" BETWEEN CENTRES
6" SWING

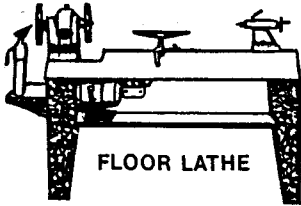

FLOOR LATHE

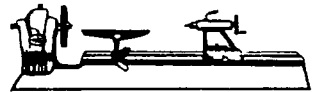

BENCH LATHE

ACCESSORIES
AVAILABLE

Manufactured by

F. & R. TOUGH PTY.
LTD.
Ironfounders, Engineers & Toolmakers
BELMONT, WESTERN AUSTRALIA

**SURFACE
MAIL**

**POSTAGE
PAID
AUSTRALIA**

559
MR W.L. NICHOLLS
68B PRESTON POINT RD
EAST FREMANTLE
W.A. 6158

RETURN ADDRESS: P.O. Box 115, KALAMUNDA, W.A. 6076.

REGISTERED BY AUSTRALIA POST. PUBLICATION N° 1883